

Pedestrian stacker truck 1.2 - 1.4 tonnes



BT staxio

W-series

SWE120

SWE140



Pedestrian stacker

Specification for stacker trucks					SWE120	SWE140
Identification	1.1	Manufacturer			Toyota	Toyota
	1.2	Model			SWE120	SWE140
	1.3	Drive			Electric	Electric
	1.4	Operator type			Pedestrian	Pedestrian
	1.5	Load capacity/rated load	Q	kg	1200	1400
	1.6	Load centre	c	mm	600	600
	1.8	Load distance, centre of support arm wheel to face of forks	x	mm	639	639
	1.9	Wheelbase	y	mm	1247	1247
	Weight	2.1	Service weight including battery		kg	929
2.2		Axle load, with load, drive/castor/support arm wheel		kg	400/290/1445	450/245/1640
2.3		Axle load, without load, drive/castor/support arm wheel		kg	400/250/285	450/200/285
Wheels	3.1	Drive/castor/fork wheel			Friction/Vulkollan/Vulkollan *)	
	3.2	Wheel size, front		mm	Ø230x70	Ø230x70
	3.3	Wheel size, rear		mm	Ø85x95	Ø85x95
	3.4	Additional wheels (dimensions)		mm	Ø125x50	Ø125x50
	3.5	Wheels, number front/rear (x = driven wheels)			1x+2/2	1x+2/2
	3.6	Track width, front	b ₁₀	mm	550	550
	3.7	Track width, rear	b ₁₁	mm	390	390
Dimensions	4.2	Height, mast lowered	h ₁	mm	2135 *)	2160 *)
	4.3	Free lift	h ₂	mm	166 *)	166 *)
	4.4	Lift	h ₃	mm	3210 *)	3165 *)
		Lift height	h ₂₃	mm	3300 *)	3255 *)
	4.5	Height, mast extended	h ₄	mm	3720 *)	3725 *)
	4.8	Stand height (optional platform)	h ₇	mm	150	150
	4.9	Height of tiller in drive position, min./max.	h ₁₄	mm	865/1235	865/1235
	4.15	Height, fork lowered	h ₁₃	mm	90	90
	4.19	Overall length	l ₁	mm	1906	1901
	4.20	Length to face of forks	l ₂	mm	758	758
	4.21	Overall width	b ₁	mm	770	770 *)
	4.22	Fork dimensions	s/e/l	mm	60/180/1150 *)	70/180/1150 *)
	4.24	Fork-carriage width	b ₃	mm	674	674
	4.25	Width over forks	b ₅	mm	570 *)	570 *)
	4.31	Ground clearance, with load, below mast	m ₁	mm	27	27
	4.32	Ground clearance, centre of wheelbase	m ₂	mm	27	27
	4.33	Aisle width for pallets 1000x1200 crossways	A _{st}	mm	2297	2297
4.34	Aisle width for pallets 800x1200 lengthways	A _{st}	mm	2286	2286	
4.35	Turning radius	W _a	mm	1397	1397	
Performance data	5.1	Travel speed, with/without load		km/h	6/6	6/6
	5.2	Lift speed, with/without load		m/s	0.12/0.28	0.11/0.28
	5.3	Lowering speed, with/without load		m/s	0.38/0.38	0.37/0.38
	5.8	Max. gradeability, with/without load		%	8/12 ¹⁾	8/12 ¹⁾
	5.10	Service brake			Electromagnetic	Electromagnetic
Electric motor	6.1	Drive motor rating S2 60 min		kW	1.0	1.5
	6.2	Lift motor rating at S3 15%		kW	2.2 ²⁾	2.2 ²⁾
	6.4	Battery voltage/nominal capacity K _s		V/Ah	24/225 *)	24/225 *)
	6.5	Battery weight		kg	219 *)	219 *)
	6.6	Energy consumption according to VDI cycle		kWh/h	0,78	—
	Others	8.1	Type of drive control			BT Powerdrive

¹⁾ Measured according to company standard

²⁾ S3 6%

*) Further alternatives are available and will produce other values.

Data is based on standard configurations: Medium battery compartment, h₂₃ = 3300 mm (SWE120) and 3255 mm (SWE140) Duplex Tele Panoramic View mast.

All data are based on table configuration. Other configurations may give other values.

Truck performance and dimensions are nominal and subject to tolerances.

Toyota Material Handling Manufacturing Sweden AB products and specifications are subject to change without notice.

Battery dependent dimensions

BT staxio

Dimensions		Battery change		SWE120			SWE140		
				Lift out		Sideways	Lift out		Sideways
		Battery compartment		Medium	Large	Large	Medium	Large	Large
1.9	Wheelbase	y	mm	1247	1297	1297	1247	1297	1297
4.19	Overall length	l ₁	mm	1906	1956	1956	1901	1951	1951
	without platform			1991/2381	2041/2431	2041/2431	1986/2376	2036/2426	2036/2426
4.20	Length to face of forks	l ₂	mm	758	808	808	758	808	808
	without platform			843/1233	893/1283	893/1283	843/1233	893/1283	893/1283
4.33	Aisle width for pallets 1000x1200 crossways	A _{st}	mm	2297	2347	2347	2297	2347	2347
	without platform			2382/2782	2432/2832	2432/2832	2382/2782	2432/2832	2432/2832
4.34	Aisle width for pallets 800x1200 lengthways	A _{st}	mm	2286	2336	2336	2286	2336	2336
	without platform			2371/2771	2421/2821	2421/2821	2371/2771	2421/2821	2421/2821
4.35	Turning radius	W _a	mm	1397	1447	1447	1397	1447	1447
	without platform			1482/1882	1532/1932	1532/1932	1482/1882	1532/1932	1532/1932
6.4	Battery voltage, nominal capacity K _s		V/Ah	24/225	24/300	24/260	24/225	24/300	24/260
6.5	Battery weight, min.—max.		kg	189—250	230—280	209—250	189—250	230—280	209—250

Mast dimensions

SWE120			Simplex	Duplex Tele			Dupl. Tele Panoram. View			Duplex Hi-Lo			Triplex Hi-Lo		
h ₂₃	Lift height (h ₁₃ +h ₃)	mm	1400 1700	2700 2900 3300 3700 4150	2700 2900 3300 3700 4150	2700 2900 3300 3700 4150	2700 2900 3300 3700 4150	2700 2900 3300 3700 4150	3300 3700 4150 4500						
h ₃	Lift	mm	1310 1610	2610 2810 3210 3610 4060	2610 2810 3210 3610 4060	2610 2810 3210 3610 4060	2610 2810 3210 3610 4060	3210 3610 4060 4410							
h ₁	Height, mast lowered	mm	1825 2125	1840 1940 2140 2340 2565	1835 1935 2135 2335 2560	1835 1935 2135 2335 2560	1835 1935 2135 2335 2560	1695 1829 1979 2095							
h ₂	Free lift, ground to top of forks	mm	1400 1700	166 166 166 166 166	166 166 166 166 166	1420 1520 1720 1920 2144	1270 1404 1554 1670								
h ₄	Height, mast extended	mm	1825 2125	3125 3325 3725 4125 4575	3120 3320 3720 4120 4570	3141 3341 3741 4141 4591	3747 4149 4599 4947								

SWE140			Duplex Tele Panoramic View					Duplex Hi-Lo					Triplex Hi-Lo				
h ₂₃	Lift height (h ₁₃ +h ₃)	mm	2655 2855 3255 3655 4105	2655 2855 3255 3655 4105	2655 2855 3255 3655 4105	2655 2855 3255 3655 4105	2655 2855 3255 3655 4105	3255 3655 4105 4455 4755									
h ₃	Lift	mm	2565 2765 3165 3565 4015	2565 2765 3165 3565 4015	2565 2765 3165 3565 4015	2565 2765 3165 3565 4015	2565 2765 3165 3565 4015	3165 3565 4015 4365 4665									
h ₁	Height, mast lowered	mm	1860 1960 2160 2360 2585	1835 1935 2135 2335 2560	1695 1829 1979 2095 2195												
h ₂	Free lift, ground to top of forks	mm	166 166 166 166 166	1374 1474 1674 1874 2099	1224 1358 1508 1624 1724												
h ₄	Height, mast extended	mm	3125 3325 3725 4125 4575	3141 3341 3741 4141 4591	3747 4149 4599 4947 5247												

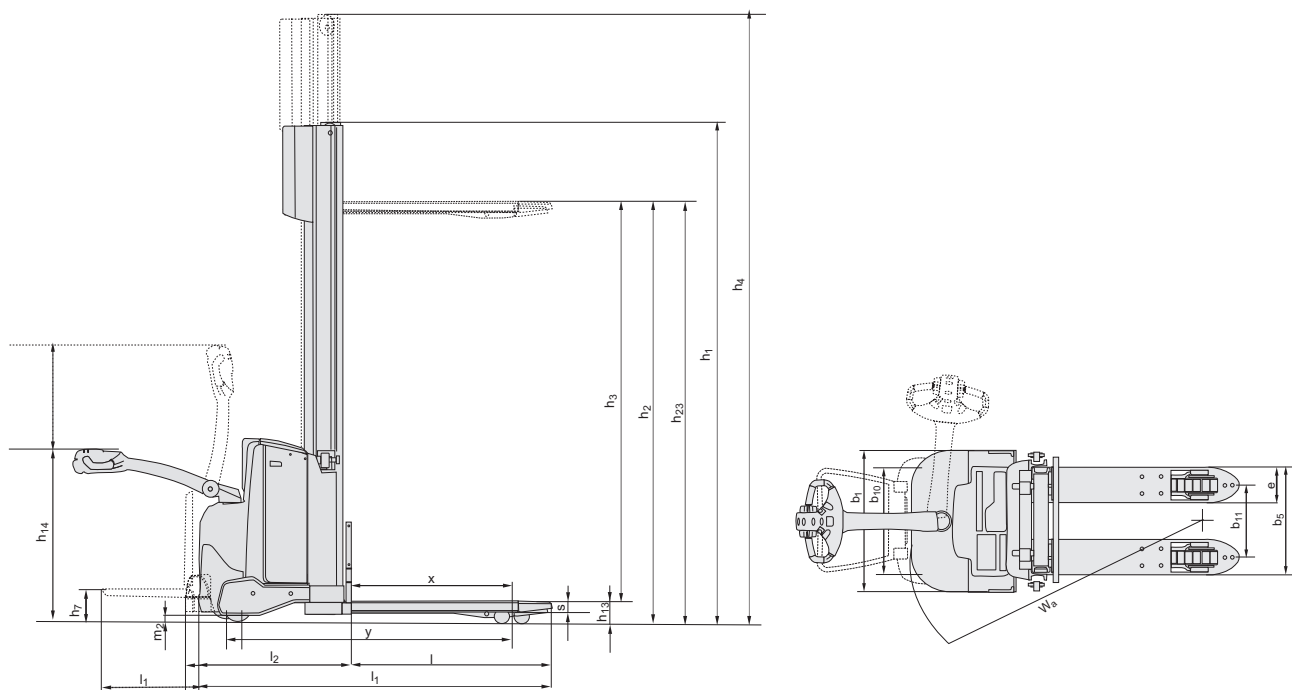

Truck features:

- BT Powerdrive System
- Fingertip controls
- Electronic braking system
- Electronic speed control
- Operator safety
- Storage compartments
- Automatic switch-off
- Click-2-creep
- Programmable performance
- Easy access for maintenance
- Built in charger (option)
- Sensilift (option)
- Flip-up operator platform (option)
- Toyota I_site: truck fleet management system (option)
- Hydraulic oil for low temperatures (option)

For more information contact:

Toyota Material Handling UK

T: 0370 850 1409

E: We.deliver@uk.toyota-industries.eu

W: www.toyota-forklifts.co.uk