

Hand pallet truck 2.0 tonne

BT lifter

with scale

LHM200SC



Hand pallet truck

Truck specifications					LHM200SC
Identification	1.1	Manufacturer			BT
	1.2	Manufacturer's type designation			LHM200SC
	1.4	Operator type			Hand
	1.5	Load capacity/rated load	Q(t)	kg	2000
	1.6	Load centre distance	c	mm	600
	1.8	Load distance, centre of drive axle to fork	x	mm	925 ¹⁾
	1.9	Wheelbase	y	mm	1170 ¹⁾
Weight	2.1	Service weight		kg	103
	2.2	Axle load, with load, drive/castor/fork wheel		kg	375/805
	2.3	Axle load, without load, drive/castor/fork wheel		kg	20/10
Wheels	3.1	Steer/fork wheels: Powerthane (Po), Steel (S), Nylon (N), Polyurethane (P), Rubber (R), Rubber antistatic (Ra)			N, P, S, Po, R, Ra / N, P, Po
	3.2	Wheel size, front			175x60
	3.3	Wheel size, rear			85x100 / 85x75 ²⁾
	3.5	Wheels, number front/rear (x=driven wheels)			2/2 or 2/4 ²⁾
	3.6	Track width, front	b ₁₀	mm	132
	3.7	Track width, rear	b ₁₁	mm	370/530
	Dimensions	4.4	Lift	h ₃	mm
		Lift height	h ₂₃	mm	205
4.9		Height of tiller in drive position, min./max.	h ₁₄	mm	1220
4.15		Height, lowered	h ₁₃	mm	90
4.19		Overall length	l ₁	mm	1520
4.20		Length to face of forks	l ₂	mm	370
4.21		Overall width	b ₁ /b ₂	mm	540/700 ³⁾
4.22		Fork dimensions	s/e/l	mm	65/170/1150 ⁴⁾
4.25		Width over forks	b ₅	mm	540/700 ³⁾
4.32		Ground clearance, centre of wheelbase	m ₂	mm	25
4.33		Aisle width for pallets 1000 x 1200 crossways	A _{st}	mm	1525 ¹⁾
4.34		Aisle width for pallets 800 x 1200 lengthways	A _{st}	mm	1725 ¹⁾
4.35		Turning radius	W _a	mm	1370 ¹⁾

1) Distance with forks raised

2) Single wheel / Bogie wheel

3) Other widths available on request

4) Other fork length available: 800/910/1000/1070/1220

All data are based on table configuration. Other configurations may give other values.

Truck performance and dimensions are nominal and subject to tolerances.

Specifications are subject to change without notice.

Scale data	Graduation multi-range			
	0 — 200		kg	0,2
	200 — 500		kg	0,5
	500 — 2000		kg	1,0
	Maximum inaccuracy, applied weight		kg	0,1
	Battery			12 Vdc/ 1,2 Ah
	Charger			230 V/ 12 Vdc

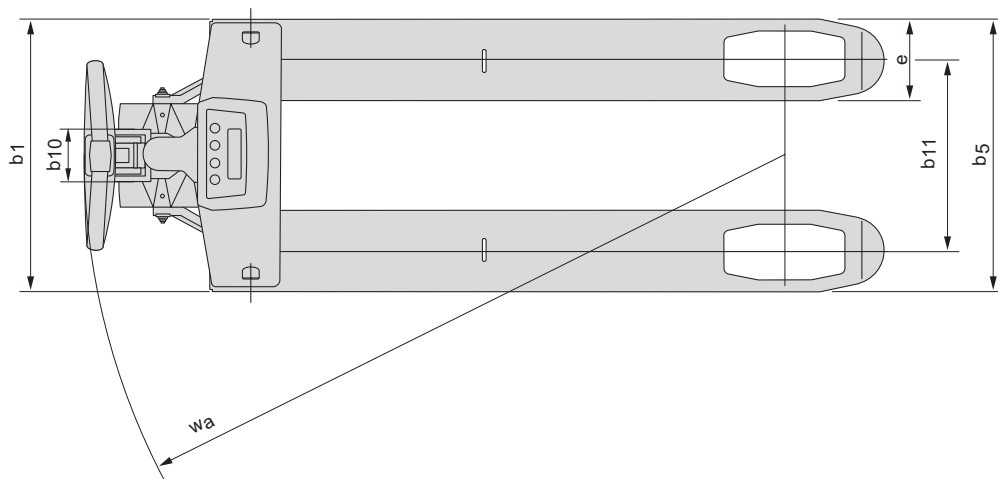
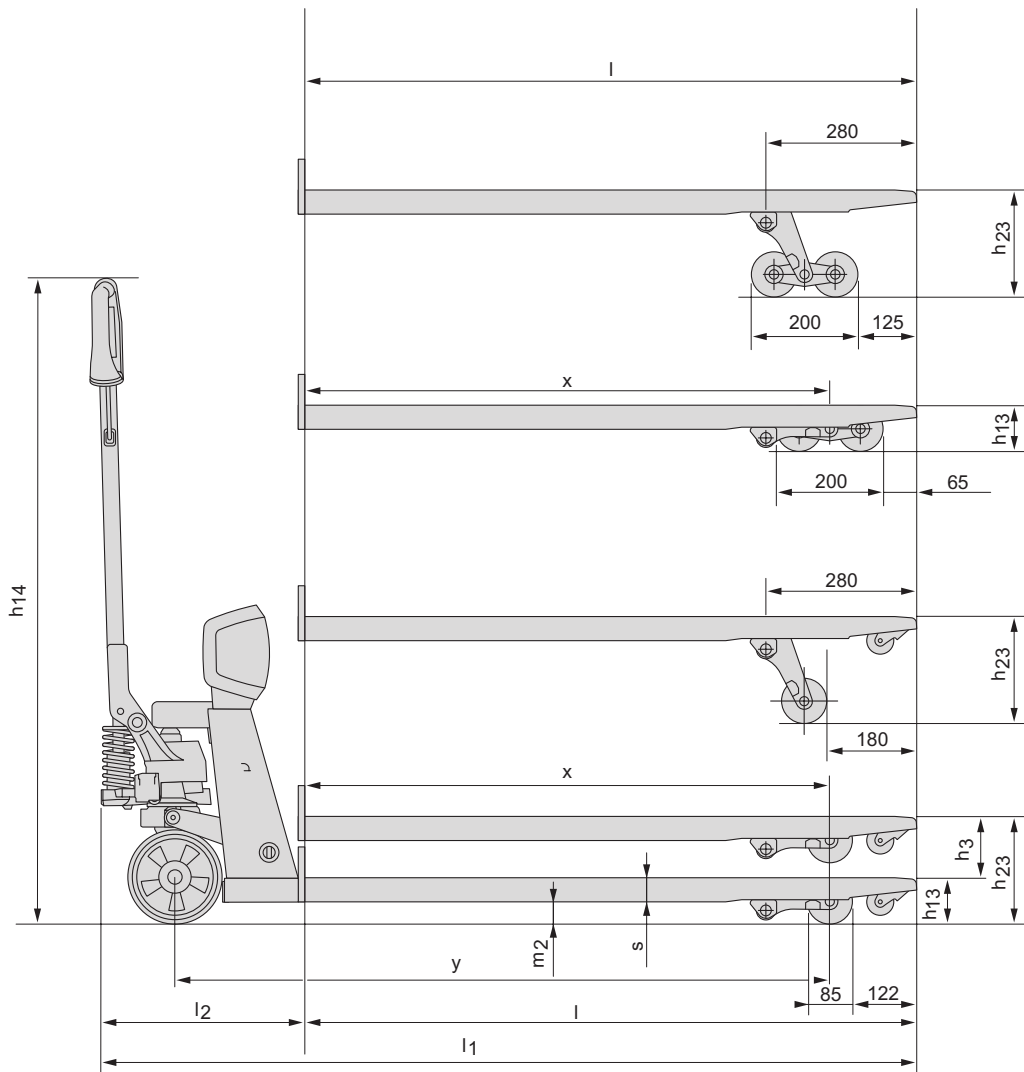

Truck features:

- The BT Lifter with scale – a mobile high precision weighing truck.
- The BT Lifter with scale is developed for industrial applications and is protected against water, dust and shocks.
- The exchangeable battery module provides for 35 hours of use, plus makes it possible to use the hand pallet truck without weighing when charging the battery.
- Legal for trade version available on request.
- Built in printer for printing weight data on site is available on request.
- Greasable bushings ensure a long service life.
- Angled high strength polymer handle for best ergonomic grip.
- This product has been environmentally declared.

For more information contact:

Toyota Material Handling UK

T: 0870 850 1400

E: we.deliver@toyota-forklifts.co.uk

W: www.toyota-forklifts.co.uk

TP-Technical Publications — 745347 - 0411



TOYOTA MATERIAL HANDLING, MANAGING THE TOYOTA AND BT MATERIALS HANDLING BRANDS

TOYOTA

MATERIAL HANDLING

stronger together