

Technical sheet

TMM 20 4W

Truck Mounted Forklifts



	Technical characteristics	Metric
1.1	Manufacturer	Manitou
1.2	Model	TMM 20 4W
1.3	Type of traction	Diesel
1.4	Type of operation	Seated
1.5	Q - Rated capacity	2000 kg
1.9	y - Wheelbase	1600 mm
Weight		
2.1	Weight of truck in working order	2250 kg
Wheels		
3.1	Tyre equipment: bandage (V), PPS (SE), inflatable tyre (L)	L
3.5	Number of front wheels (x)	2x / 1x
Dimensions		
4.2	h1 - Height (mast lowered)	2350 mm
4.5	h4 - Height of extended mast	4450 mm
4.7	h6 - Height of driver protection (cab)	2080 mm
4.19	l1 - Total length	2600 mm
4.20	l2 - Length to fork heel	1400 mm
4.21	b1 - Overall width - Single/twinned wheels	2320 mm / -
4.24	b3 - Width of fork clamp	1260 mm
4.34	Ast - Aisle width for 800 x 1200 pallet lengthwise	3360 mm
4.35	Wa - Turning radius	2460 mm
Performances		
5.1	Speed of travel laden / unladen	10 km/h / -
5.10	Service brake	Oil-Immersed Multi-Discs on Front & Rear Axles
Engine		
7.1	Engine manufacturer / Type	Kubota - V1505 / Stage 3A / Interim Tier IV
7.2	Useful power	26.50 kW
7.4	Number of pistons / Capacity	4 / 1498 cm ³
Miscellaneous		
8.2	Working hydraulic pressure for attachments	190 bar
8.3	Oil flow rate for attachments	43 l/min

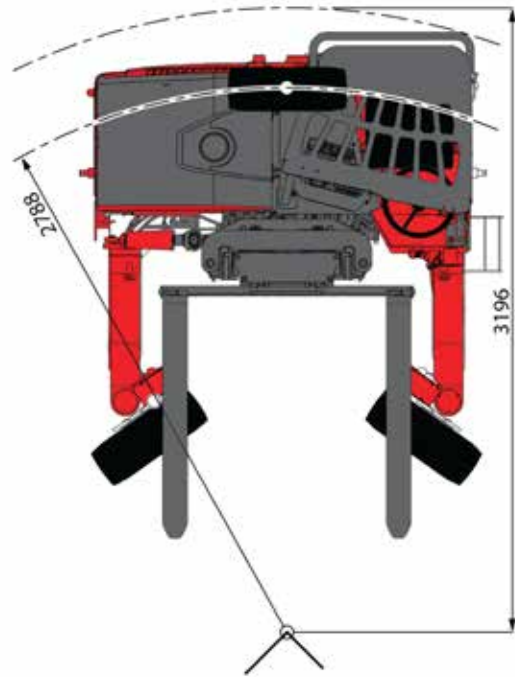
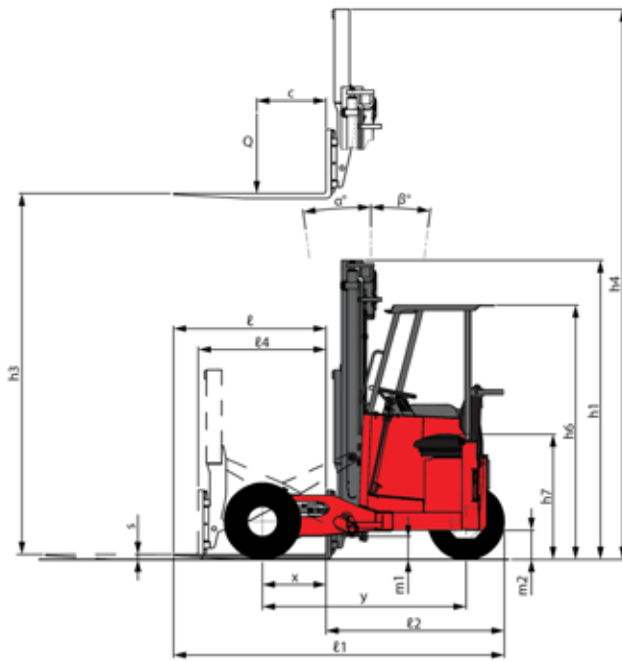

Characteristics of masts and residual capacities

Duplex Total Visibility		FVD 30	FVD 36
Lift height	mm	3000	3600
Height (mast lowered)	mm	2352	2702
Height of extended mast	mm	4455	5055

Equipment

Standard

3 braked wheels

3 drive wheels with hydrostatic transmission

Barre arrière de protection

Battery Master Switch

Belt-linked engine cut-off

Wide handle

Three-function FNR handling levers

Anti-slip step

4 Way System

24V 2x7 plug truck connector adapter

Certified driver guard

Left-hand safety strap

Imitation leather seat

Stabiliser on front wheel arms

License plate quick change bracket and light

Optional

Reversing warning buzzer

Hydraulic line for quick-release attachments

Complete road lighting

Extenseur

Reversing light

Flashing Light

Telescopic Forks

Extreme cold diesel fuel

Rotating beacon light

6 km/h forward and reverse speed limiter

Metal plating

Personalized paintwork

Rear working light

Right front working light

Left front working light

Self-cleaning pre-filter

24V 1x15 plug truck connector adapter

Transparent roof protection

Outside right rear-view mirror

Internal rear-view mirror



Groundwater Lift Trucks Ltd,
Spurryhillock Industrial Estate,
Stonehaven, Aberdeenshire, AB39 2NH
01569 763247
sales@groundwater.uk.com
www.groundwater.uk.com



Siège Social
430 rue de l'Aubinière - 44150 Ancenis Cedex - France
Tel: +33(0)2 40 09 10 11 - Fax: +33 (0)2 40 09 10 97
www.manitou.com



This brochure describes versions and configuration options for Manitou products which may be fitted with different equipment. The equipment described in this brochure may be standard, optional or not available depending on version. Manitou reserves the right to change the specifications shown and described at any time and without prior warning. The manufacturer is not liable for the specifications given. For more information, contact your Manitou dealer. Non-contractual document. Product descriptions may differ from actual products. List of specifications is not comprehensive. The logos and visual identity of the company are the property of Manitou and may not be used without authorisation. All rights reserved. The photos and diagrams contained in this brochure are provided for information only.

MANITOU BF SA - Limited company with board of directors - Share capital: 39,547,824 euros - 857 802 508 RCS Nantes